

Operator Manual

Pocket MFSHL Systems



Pocket MFSHL V1

Pocket MFSHL V2

Pocket MFSHL V3

Pocket MFSHL V5

www.hetronic.com

YOUR #1 PARTNER IN RADIO REMOTE CONTROLS

Hetronic USA

4300 Highline Blvd., Bldg. A
Oklahoma City, OK 73108
405-946-3574 Fax 405-946-3564

Hetronic Canada

45 Sinclair Avenue
Halton Hills, Ontario L7G 4X4
+1-800-816-4459 Fax +1-905-702-0501

INTRODUCTION

INTRODUCTION

Thank you for purchasing the Hetronic radio remote control system. Hetronic radio remote controls are the highest caliber in remote control value, performance and safety.

Hetronic radio remote controls use the latest frequency synthesizer technology to eliminate the problems typically associated with radio remote control systems.

THE MANUAL

Before operation of the crane/machine and remote control system, read your manuals carefully and completely. The contents of this manual will provide you with an understanding of safety instructions and controls during normal operation and maintenance.

PRODUCTION AND SYSTEM NUMBERS

When contacting your dealer or Hetronic about service, repair or replacement parts, know the Production and System numbers of the transmitter and receiver.

The numbers are located on the label that is affixed to the unit itself.

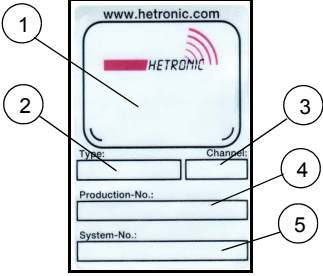

The diagram shows a rectangular label with the following fields and callouts:

- 1: Points to the top section containing 'www.hetronic.com' and the 'HETRONIC' logo.
- 2: Points to the 'Type:' field.
- 3: Points to the 'Frequency' field.
- 4: Points to the 'Production-No.:' field.
- 5: Points to the 'System-No.:' field.

1. Specific approvals such as BTZ, FCC, CE, etc.
2. The type of transmitter or receiver.
3. Frequency and RF unit.
4. Production number.
5. **System Number** - The Hetronic part number of the transmitter or receiver.

Record the Production and System numbers here:

Transmitter Production Number

Receiver Production Number

System Number

UNAUTHORIZED REPLACEMENT PARTS

Use only Hetronic replacement parts. The replacement of any part with anything other than a Hetronic authorized replacement part may adversely affect the performance, durability, and safety of this system and may void the warranty. Hetronic disclaims liability for any claims or damages, whether warranty, property damage, personal injury or death arising out of the use of unauthorized replacement parts.

BEFORE ATTEMPTING TO OPERATE THIS SYSTEM:

1. Make sure all installation has been properly completed.
2. Understand all safety precautions provided in the manuals.
3. Review control functions and operation of the crane/machine and this radio remote control system.
4. When not in use, remove the transmitter batteries and store in a safe place to prevent unauthorized use.
5. If the crane/machine does not respond properly, stop operation immediately. Remove the transmitter batteries and report the condition to the appropriate technician or supervisor.
6. Remove the transmitter batteries and disconnect power to the receiver before any maintenance work is done.
7. When using rechargeable batteries always have batteries in the battery charger to ensure the availability of fully charged batteries.
8. Installation, setup and service must be performed by authorized personnel only.
9. Use only Hetronic spare parts.

HETRONIC SYSTEM COMPONENTS

The Hetronic radio remote control system consists of a receiver and transmitter.

RX MFSHL AC8 Receiver Standard Features

- MFS technology with H-Link programming
- 8 solid state switching outputs
- Safety output monitoring
- 48/220 VAC

RX MFSHL DC8 Receiver Standard Features

- MFS technology with H-Link programming
- 8 solid state switching outputs
- safety output monitoring
- 12/24 VDC

RX MFSHL AC16 Receiver Standard Features

- MFS technology with H-Link programming
- 16 solid state switching outputs
- safety output monitoring
- 12/24 VDC

Pocket MFSHL V1 Transmitter Standard Features

- MFS technology with H-Link programming
- E-stop pushbutton
- Two dual-speed motion pushbutton
- One on/off start/horn pushbutton
- 30 m (100 ft.) range
- Internal antenna

Pocket MFSHL V2 Transmitter Standard Features

- MFS technology with H-Link programming
- E-stop pushbutton
- Four dual-speed motion pushbuttons
- One on/off start/horn pushbutton
- 30 m (100 ft.) range
- Internal antenna

Pocket MFSHL V3 Transmitter Standard Features

- MFS technology with H-Link programming
- E-stop pushbutton
- Six single-speed motion pushbuttons
- One on/off start/horn pushbutton
- 30 m (100 ft.) range
- Internal antenna

Pocket MFSHL V5 Transmitter Standard Features

- MFS technology with H-Link programming
- E-stop pushbutton

- Six dual-speed motion pushbuttons
- One on/off start/horn pushbutton
- 30 m (100 ft.) range
- Internal antenna

SYSTEM OVERVIEW

Theory of Operation

The Hetronic radio remote control system includes a transmitter and receiver. The transmitter electronically generates a carrier frequency which allows it to communicate with the receiver. Each system is programmed with a unique address code. This code allows the operation of multiple systems in the same general vicinity. The receiver only accepts commands from the transmitter with the same address code.

MFS Transmission Technology

All Pocket MFSHL systems utilize Hetronic's advanced Multiple Frequency Sharing (MFS) technology. MFS technology allows for multiple systems to operate on a single frequency in an enclosed area with virtually no worry about same system interference.

H-Link Technology

All Pocket MFSHL systems utilize Hetronic's new H-Link wireless system access and parameter programming. H-Link allows for wireless access to all system programming parameters via a Personal Digital Assistant (PDA)/Pocket PC.

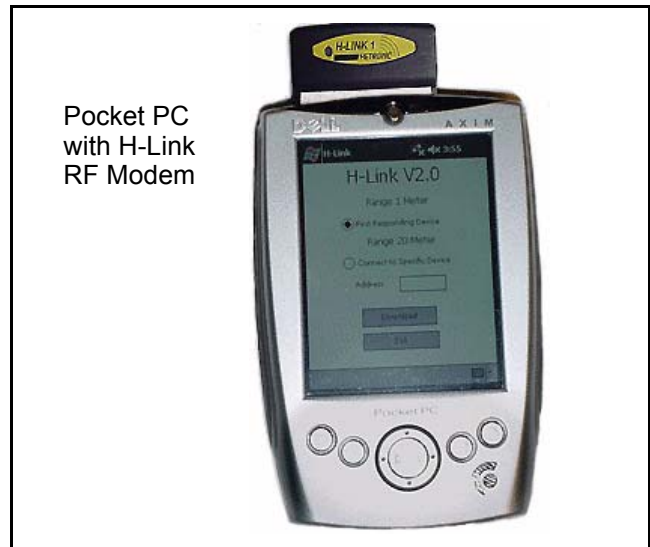

E-Stop Function

The most important feature of the radio remote control system is the E-Stop. The transmitter sends the E-stop status signal along with the specified crane/machine function. This method confirms that ongoing operations are safe. When wired correctly, pressing the E-stop pushbutton opens the main contact output in the receiver, causing all crane/machine motions to stop. The receiver immediately goes into E-Stop. To restart the system, just press the Start/Horn button.

The E-Stop responds faster than any other function. E-Stop must be disengaged before the system will respond to any other signal.

The E-Stop is self-monitoring. The system performs a self-test to ensure the E-Stop circuit is working properly. If an error is detected, the system automatically goes into Safe mode.

When the transmitter is turned on, it performs a self-test to ensure that the circuitry is within designated parameters. If an error is detected, the transmitter will not transmit any signals.

Receiver Safe Mode

The following conditions cause the receiver to go into its Safe mode:

- Radio signal interference
- Transmitter out of operating range
- E-Stop circuit failure
- Low battery sends E-stop after time out

When the transmitter is turned off (batteries removed), there is no radio communication between the transmitter and receiver.

SAFETY

SAFETY ALERTS



Look for this symbol to point out important safety precautions. They mean:

Attention!

Personal Safety Is Involved!

Become Alert!

Obey The Message!

The safety alert symbol is used in decals on the unit and with proper operation procedures in this manual. Understand the safety message. It contains important information about personal safety on or near the unit.



DANGER: IMMINENTLY HAZARDOUS SITUATION! If not avoided, WILL RESULT in death or serious injury.



WARNING: POTENTIALLY HAZARDOUS SITUATION! If not avoided, COULD RESULT in death or serious injury.



CAUTION: POTENTIALLY HAZARDOUS SITUATION! If not avoided, MAY RESULT in minor or moderate injury. It may also be used to alert against unsafe practices.

NOTATIONS

NOTE: General reference information for proper operation and maintenance practices.

IMPORTANT: Specific procedures or information required to prevent damage to unit or equipment.

PRACTICES AND LAWS

Practice usual and customary safe working precautions for the benefit of yourself and others. Understand and follow all safety messages. Be alert to unsafe conditions and the possibility of minor, moderate, or serious injury or death. Learn applicable rules and laws in your area.

REQUIRED OPERATOR TRAINING

Original purchaser of this unit was instructed by the seller on safe and proper operation. If unit is to be used by someone other than the original purchaser; or is loaned, rented or sold, ALWAYS provide this manual and any needed safety training before operation.

ALWAYS review the operator's manual of any crane/machine to be controlled by radio remote control.

POSSIBLE SOURCES OF DANGER

This system makes remote control via radio signals possible. The transmission of control commands can take place around obstacles and out of the operator's direct sight. To prevent accidental start-up and possible injury or damage:

1. Always engage the E-stop button and remove battery from the transmitter when it is not in use or if the unit is placed any distance away from the operator.
2. Disconnect the receiver power supply before any assembly, maintenance or repair work is done.

IMPORTANT: AVOID SYSTEM DAMAGE - ALWAYS disconnect receiver power supply and control wiring before welding on any part of the crane/machine.

3. Never remove or alter any of the safety features of this system.

OPERATION AND WORK AREA SAFETY

The work area must be free from obstacles, debris or other tripping hazards. Avoid uneven work areas and any rough terrain. Always be sure of your footing.

Be aware of overhead obstacles that may interfere with crane/machine operation.

PROTECTIVE FEATURES

This radio remote control system is equipped with electronic and mechanical safety features. Processing control signals transmitted from other transmitters is not possible, since transmission coding is unique to each system.

These safety features help protect the operator, as well as others within the work area. The crane/machine functions can be stopped by pushing the emergency stop button on the transmitter control panel (EMERGENCY STOP).

NOTE: The receiver goes into E-stop immediately after the E-stop button on the transmitter is activated.



WARNING: Accidental start-up can cause serious injury or death. NEVER remove or modify any safety feature.

TO STOP IN AN EMERGENCY

1. Press the red "STOP" pushbutton.

2. Wait for all moving crane/machine parts to stop.
3. Refer to crane/machine's operator manual for further instructions.

MAINTENANCE

Always shut off power to the crane/machine and the radio remote control system before any assembly, maintenance or repair.

IMPORTANT: AVOID SYSTEM DAMAGE - ALWAYS disconnect receiver power supply and control wiring before welding on any part of the crane/machine.

RECEIVER INSTALLATION



WARNING: FAILURE TO FOLLOW INSTRUCTIONS could result in personal injury and/or damage to equipment. Read and understand the safety instructions in all manuals provided.

Initial setup or service work must only be performed by authorized personnel.

DO NOT touch any circuit components on the circuit board while the main AC or DC power is on.

DO NOT run control wires with power wires.

Surge suppressors (RC type) must be used with all magnetic contactors that are controlled by the radio remote control system.

RECEIVER LOCATION

Select a position for the receiver that is easily accessible and provides protection from violent impact from debris or thrown materials. The receiver housing is rated IP65 and can withstand direct water jet spray and is protected against penetration of dust. All receivers must be free from metal obstructions on at least 3 sides with the antenna pointing straight up.

- Receiver must be protected from corrosive gases or liquids
- Receiver must be protected from ambient temperatures outside the range of -18° to 160° F (-25° to +70° C)

Receiver Production Number

Locate the Hetronic Production number decal on the receiver housing. This number is required when Hetronic is called for any service or parts information. Be sure the decal is easily accessible when the receiver is mounted to the equipment. Please make a note of the Production and System numbers in the boxes provided in the Introduction Section of this manual.

MOUNTING THE RECEIVER

1. Determine the receiver position.
2. Be sure there is clearance for connectors and components that need to be wired.
3. Drill holes into the mounting surface according to the dimensions shown.
4. Insert the mounting screws through the holes in the receiver housing and tighten into the mounting surface.
5. Please refer to the appropriate illustration for mounting dimensions. Contact Hetronic for more information or if you have questions.
6. Lay out the wire runs. Use #16 AWG (size 1.5 mm² metric) minimum for power wiring.
7. The area around the receiver should be free of obstructions, especially metal.

Receiver Housing

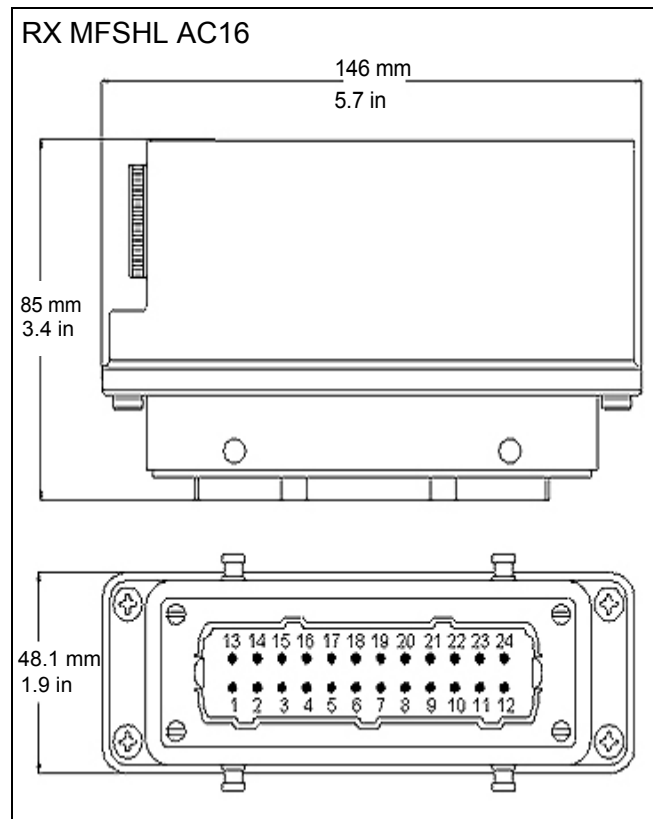
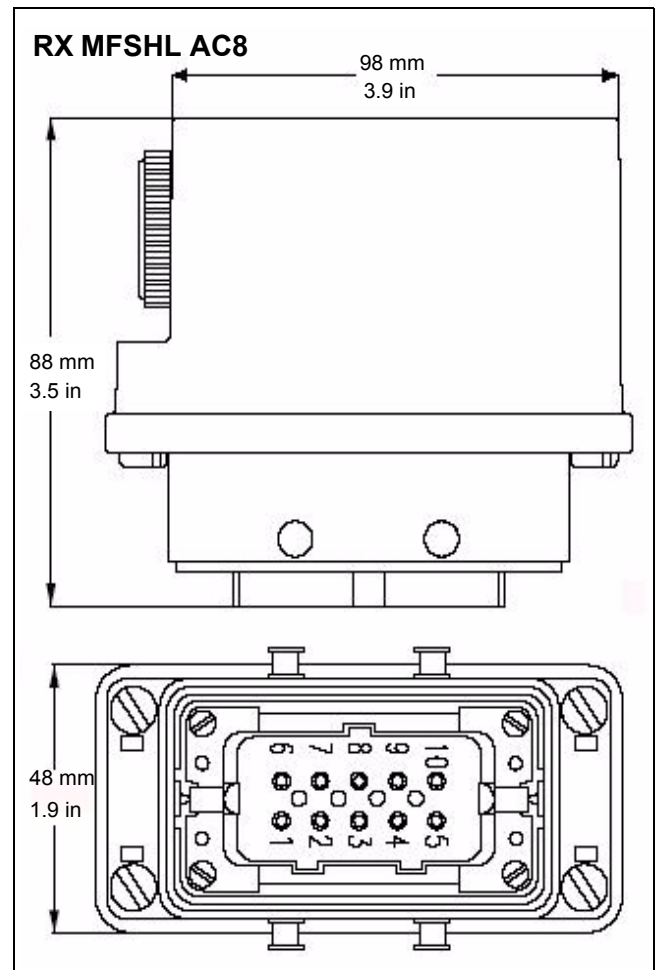
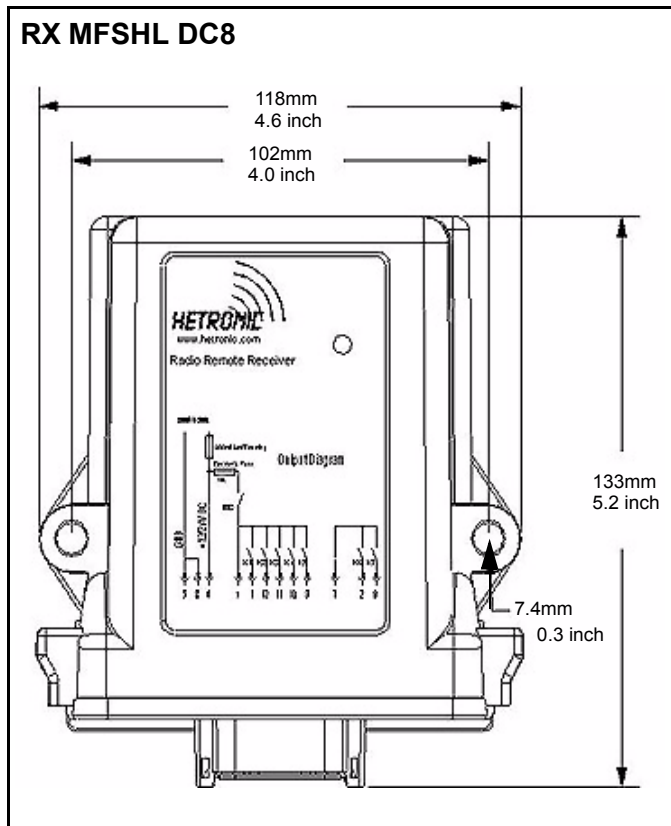

The receiver wiring is critical for proper system operation. Make all connections with good quality contacts or solder joints to ensure proper electrical contact.

Supply voltage and ground wiring are crucial and must be connected to reliable connecting circuitry. Do not use a chassis ground for this equipment. The ground wire must be connected directly to the crane/machine's ground.

CONNECT ELECTRICAL WIRING

Connect all remaining wires (power supply, engine start-stop, etc.) according to the wiring diagram of the crane/machine and the radio remote control.

Quick-Disconnect Plug

Hetronic offers a plug receptacle kit with the RX MFSHL DC8 receivers. The installer must wire the female quick-disconnect plugs and terminate them to the crane/machine controls.

Wire Terminations

Refer to the wiring diagram on this page, which is also provided with your system.

The male and female connector module pins are labeled. The connectors use numeric numbering, i.e. 1, 2, 3, 4, etc.

Receiver Wiring Diagram

RX MFSHL AC16

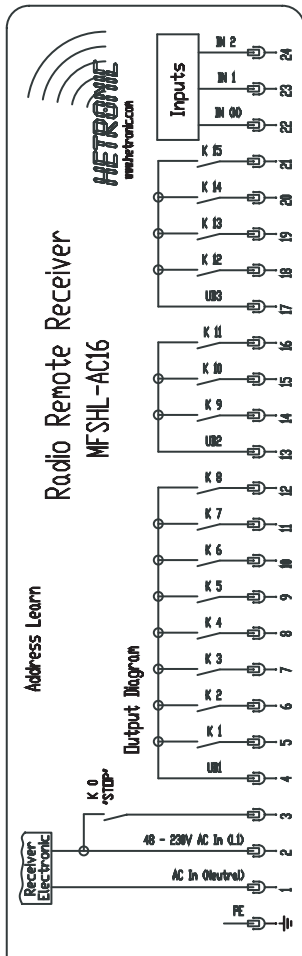

RX MFSHL DC8

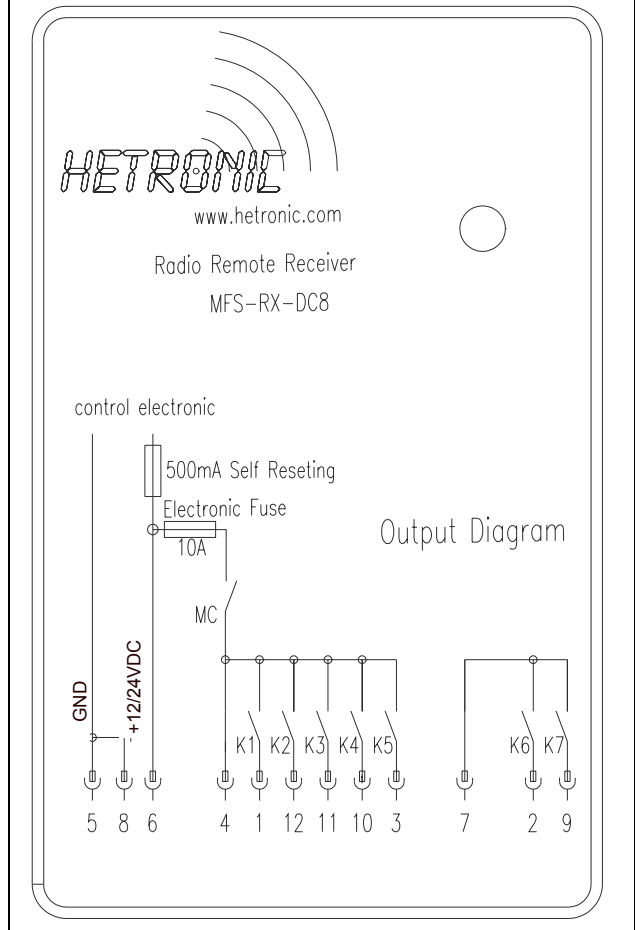

RX MFSHL AC8

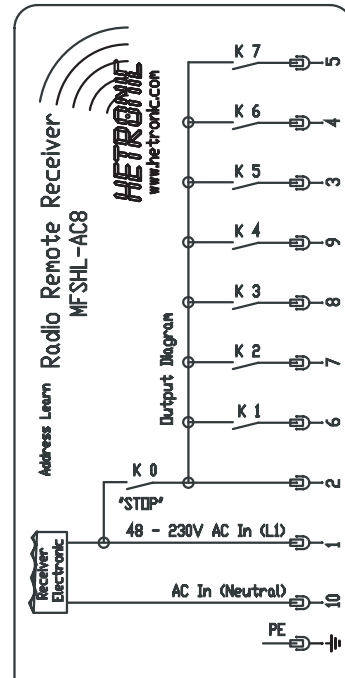

POCKET TRANSMITTERS

Each Hetronic radio remote control system is delivered with three alkaline batteries. These are inserted in the battery compartment located on the bottom side of the transmitter.

Please note that the actual configuration of each radio remote control system may vary from the illustrations shown in this manual. Refer to the technical documentation provided with each system for the actual design, layout and components.

FREQUENCY AND ADDRESS SETTINGS

Each Hetronic radio remote control system contains a radio frequency (RF) unit. Each system consists of a transmitter RF unit and a receiver RF unit.



CAUTION: AVOID INJURY OR DAMAGE - Operating the transmitter without its antenna could destroy the final stage of the RF module. DO NOT attempt to change the Hetronic pre-set frequency or the 20-bit address. Personal injury and property damage could result from transmission interference and may void the warranty.

Both Frequency and Address settings are uploaded to the system using the new H-Link wireless technology. These are preset at the factory and are password protected. Refer to the Pocket MFSHL H-Link Programming Manual for more details.

IMPORTANT: The Address and Frequency settings for both the transmitter and receiver must match; otherwise, the system will not function.

DK ASSIGNMENTS

POCKET MFSHL V1



POCKET MFSHL V3



POCKET MFSHL V2



POCKET MFSHL V5



TEST PROCEDURES



WARNING: FAILURE TO FOLLOW INSTRUCTIONS could result in personal injury and/or damage to equipment. Read and understand the safety instructions in all manuals provided.

Testing or service must be performed by authorized personnel only.

There must be no load on the crane/machine.

Clear the crane/machine operating area of obstructions.

Check the following list before turning on power to the receiver.

1. Be sure there are fully charged batteries in the transmitter. Refer to "Changing the Battery" on page 14.

HOLDING THE TRANSMITTER

Hold the transmitter with the control panel facing you. Be sure that you are able to easily read any text and understand operation symbols.



WARNING: FAILURE TO FOLLOW INSTRUCTIONS could result in personal injury and/or damage to equipment. Always hold the transmitter in the proper orientation. Holding the transmitter improperly while operating the crane/machine could result in unexpected crane/machine response.

TEST THE SYSTEM

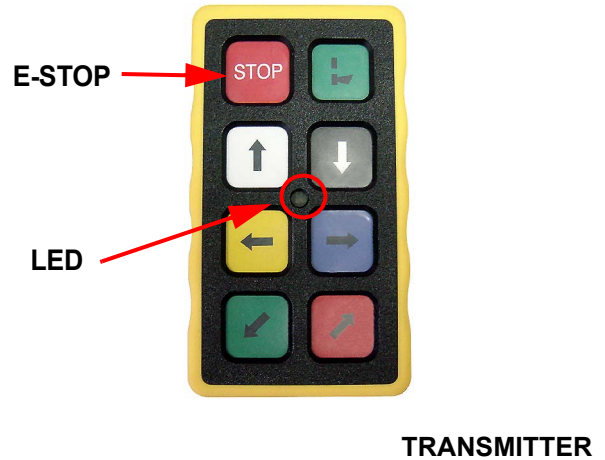

IMPORTANT: The crane/machine functions will operate during this check. Be certain that there are no obstacles near the crane/machine.

1. Position yourself in front of the receiver so that the LED is visible.
2. Apply power to receiver.
 - The LED should start flashing yellow to indicate that it is operating properly.
3. Press and release any pushbutton on the transmitter.
 - The LED on the transmitter should flash green. The duration of the flashing is determined by the "TX Shutdown" setting in the H-Link program. Refer to the Pocket MFSHL H-Link Programming Manual.
 - The LED on the receiver should flash green/yellow alternately when the button on the transmitter is pressed. This indicates that the receiver is detecting a valid signal from the transmitter.
4. Press any motion pushbutton on the transmitter again, but this time push in the E-Stop button while the green LED is flashing. Any machine movement should stop.
 - The LED on the transmitter should turn red and immediately turn off. This indicates that the E-Stop contact is open. (crane/machine motions will NOT operate)
 - The LED on the receiver should flash yellow.

5. Press one of the motion pushbuttons on the transmitter. There should be NO movement of the crane/machine motions with the E-Stop pushbutton activated.

IMPORTANT: If any function of the crane/machine radio remote control activates with the E-Stop engaged, the radio remote control must not be used until it is repaired by a certified technician.

6. Press the start button. This de-activates the E-Stop.
7. Press the appropriate motion pushbuttons to test the crane/machine functions.
8. Confirm that the crane/machine moves appropriately.
9. If both transmitter and receiver function properly, the system is ready for use.
10. If the receiver or transmitter does not operate properly, or if the crane/machine does not react as directed, shut the entire system down and refer to the Troubleshooting Section of this manual. If necessary, contact Hetronic or an authorized service technician.

OPERATION



WARNING: FAILURE TO FOLLOW INSTRUCTIONS could result in personal injury and/or damage to equipment. Read and understand the safety instructions in all manuals provided.

The safety checks described in the following paragraphs must be completed before the radio remote control system is activated. These checks must be performed at least once a day, before the start of any operation and at all shift changes.

IMPORTANT: A transmitter drawing is included with each system. Transmitter layout and inscriptions may vary according to customer requests.



WARNING: FAILURE TO FOLLOW INSTRUCTIONS could result in personal injury and/or damage to equipment. Test the "E-STOP" function as described in the crane/machine manufacturer's operator manual before beginning any operation.

VISUAL CHECK

Always check the transmitter for any physical damage before any operation.

- Always keep crane/machine safety features, guards and controls in good repair, in place and securely fastened.
- Check crane/machine and radio remote control system for wear or damage.

IMPORTANT: Never operate a transmitter with worn or damaged parts. Replace immediately with only Hetric parts. Contact Hetric or your Dealer.

1. Emergency stop button.
2. Start/Horn button
3. Pushbuttons S1 to S8. Up to 8 pushbuttons possible (including E-Stop and Start/Horn) according to version (see Transmitter drawings)
4. Battery compartment



Pocket MFSHL V3 shown

START-UP PROCEDURE

This procedure must be carefully followed before beginning any operation.

1. Be sure that all safety measures required by the equipment manufacturer have been followed.
2. Press E-stop pushbutton on the transmitter.
3. Be sure that the transmitter batteries are fully charged and inserted into the transmitter.
4. Press the start pushbutton to de-activate the E-Stop.
5. Check that the crane/machine functions correspond with the transmitter functions.

IMPORTANT: The crane/machine functions will operate during this check. Be certain that there are no obstacles near the crane/machine.

6. Press the "E-STOP" pushbutton on the transmitter. Be sure that no functions can be activated with the "E-STOP" button activated.

IMPORTANT: If any function of the radio remote control activates with the "EMERGENCY STOP" engaged, the radio remote control must not be used until it is repaired by a certified technician.

7. Press the start pushbutton to de-activate the E-Stop.
8. Both the radio remote control and the crane/machine are now ready for operation.

IMPORTANT: To avoid accidental start-up, always engage the E-stop pushbutton and remove the batteries when not in use.

	<p>WARNING: TO AVOID SERIOUS INJURY OR DEATH. Switch the crane/machine "OFF" and remove the batteries from the transmitter if there is a fault or any problems with the safety check. Contact Hetric or your dealer immediately to repair the system. NEVER operate the crane/machine when the "EMERGENCY STOP" function does not operate properly.</p> <p>Improper operation, maintenance or adjustment may cause serious injury or damage to equipment and may void the warranty.</p>
---	--

EMERGENCY STOP

For all emergency situations, press the E-Stop pushbutton. Be sure any dangerous conditions are corrected. To restart the system, press the start button to disengage the E-Stop, and then follow the Start Up Procedure above.

SAFE MODE

The transmitter will automatically go into Safe Mode when the battery voltage drops below the setting specified in the Low Voltage Warning Time in the H-Link software. During the safe mode, place the crane/machine in a safe position. After the set time, the transmitter sends the E-Stop signal and all crane/machine motion commands are stopped.

Refer to Pocket MFSHL H-Link Programming Manual for details on setting the Low Voltage Warning Time.

To restart the system, new batteries must be inserted into the transmitter. Proceed with startup instructions.

TRANSMITTER SHUTDOWN

To shut down the transmitter, press the E-Stop pushbutton and remove the batteries.

SWITCH ERROR DETECT

The unit contains a switch detection that detects when a switch is broken. If a switch is active when the batteries are inserted, the unit will go into an error state. The red LED will come on and stay on until the active switch is turned off.

LED DESCRIPTION

Indicator (LED/Buzzer) functions are:

TRANSMITTER	Red LED	Green LED	Buzzer
Low Battery	On	Blinking	Beep
TX - Fail	On	On	On
Normal TX	Off	Blinking	Off
E-STOP TX	Blinking	Off	Off

RECEIVER	Red LED	Green LED	Yellow LED
Main Contact Error	On	Off	Off
RX Active	Off	Off	Blinking
RX Receiving	Off	Blinking	Off

PROGRAMMABLE FEATURES

For the transmitter, programmable features include TX Shutdown, Duty Cycle, and Low Voltage Warning Time.

For the receiver, programmable features include Communication Timeout, Main Contact Timeout, I/O Logic, Output Assignment, Output Settings, and Output Interlocking. Refer to Pocket MFSHL H-Link Programming Manual for more details.

SAFETY FEATURES

Interlocking Functions

This feature allows the digital output of the receiver to be interlocked and prevents contradictory operator commands from the transmitter. Certain functions can be enabled or disabled when another function is activated or inactive.

Low Voltage Warning Time

This feature is programmable using the H-Link software interface. The time/voltage setting may be selected to specify when the low battery indicator (LED) illuminates before the battery is completely discharged. This feature is beneficial where placing the crane or machine in a safe position takes more time after the low battery is indicated. If the voltage level reaches a critical level, the transmitter will only send E-stop telegrams. Refer to Pocket MFSHL H-Link Programming Manual for more details.

MAINTENANCE

CHANGING THE BATTERY

The battery voltage is monitored continuously by the transmitter.

When the battery is nearly discharged, the LED on the transmitter will turn red and the buzzer will sound.

When the batteries are low, they need to be changed immediately.

1. Position the crane/machine into a safe place or safe condition within a set amount of time after a visual notice is given. This time setting is programmable under the "Low Voltage" option in the H-Link software. Refer to the Pocket MFSHL H-Link Programming Manual.



WARNING: The transmitter will switch to the EMERGENCY STOP condition after the set amount of time expires.

2. Press the E-stop pushbutton.
3. Remove the discharged batteries.
4. Insert new batteries.

NOTE: Commercially available rechargeable batteries may be used.

5. Follow "Start-up Procedure" to begin operation.

Replacing the Alkaline Batteries:

1. Slide out the battery compartment cover on the bottom side of the transmitter as shown.
2. Remove the three discharged alkaline batteries.
3. Insert three new 1.5V alkaline batteries into the battery compartment, following the polarity indicated inside the battery compartment wall.

NOTE: Be sure that you only use alkaline batteries.

4. Replace the compartment cover onto the transmitter and snap it into place.

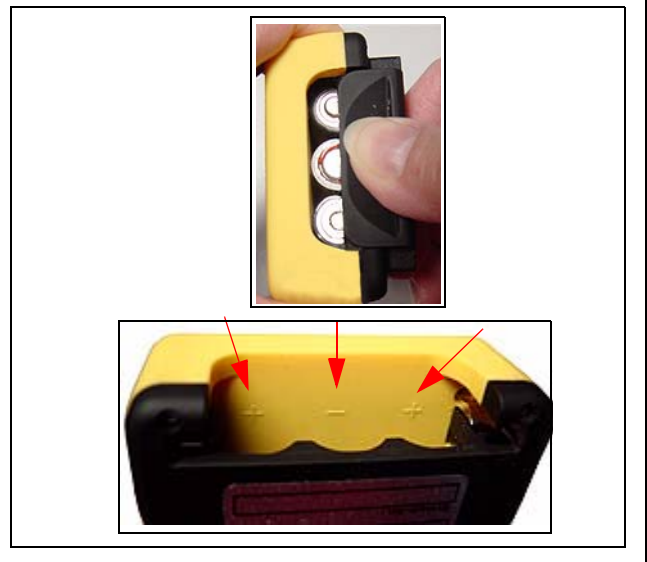

BATTERY DISPOSAL

IMPORTANT: AVOID ENVIRONMENTAL POLLUTION. Electronic equipment and components are considered to be hazardous waste. Discarded batteries are hazardous waste and must not be disposed of with typical refuse. Contact a professional hazardous waste disposal service.



WARNING: EXPLOSIVE GASES AND FLYING DEBRIS can cause death or serious injury. Use of unauthorized replacement batteries could cause a battery explosion, resulting in injury or death of the operator or other people in the work area.

TROUBLESHOOTING

If the system does not operate after normal start-up as described in the Operation Section of this manual, follow the recommended troubleshooting sequence to help isolate the cause and determine corrective action.

If the system will not respond to the steps below or the LEDs indicate a failure, contact the Hetronic Service Department or your authorized dealer.

NOTE: Refer to page 13 for LED description.

If a call to Hetronic Service or your Dealer is required, please have the transmitter and receiver Production and System numbers available. You should also be able to answer the following questions.

Transmitter

- Is the E-Stop pushbutton disengaged?
- Are the batteries in the transmitter fully charged?
- Is the transmitter inside its operating range?

Receiver

- Are the power supply and ground wires securely fastened?
- Are the signal wires separated from the power supply wires?

Please check these items and have the transmitter and receiver Production and System numbers available when placing a call to Hetronic or your Dealer.

PROBLEM	PROBABLE CAUSE	CORRECTION
System will not operate after normal start-up procedure	E-Stop switch engaged	Press the start button to disengage E-stop.
	Batteries fully discharged	Check batteries to ensure a full charge. Replace with new batteries if necessary.
	No power to the receiver	Check the diagnostic LED on the receiver to be sure power is applied. Ensure that the system is properly grounded.
Transmitter is transmitting (Power LED flashing), but crane/machine will not respond	E-Stop switch engaged	Press the start button to disengage E-Stop.
	Transmitter out of range	Take the transmitter back into the range of the receiver.
	Receiver power off	Turn on power to receiver.
	E-Stop failure in transmitter	Check E-Stop pushbutton for damage. Check wiring to contact element for broken or disconnected wires. Repair or replace E-stop pushbutton or wiring.
All crane/machine motions operate intermittently	Ground wiring is poor. Conductor is too small, or receiver is grounded to chassis.	Ground wiring must be connected to machine power source ground. Minimum diameter of conductor ground is 12 AWG.
Some crane/machine motions operate intermittently	Crane/machine motion wiring may be loose.	Check wiring from receiver to plug and from plug to crane/machine motion actuator.

SPECIFICATIONS

SYSTEM

Operating range	100 ft (30 m) typical
Frequency range	311/315 MHz, 868MHz, or 916MHz
HF output power	2 - 3 mW
Operating temperature range	-25° to +70° C (-18° F to 158° F)
Enclosures	IP65 weatherproof (exceeds NEMA 12/13)
Programmable	I/O Logic, Interlocking, Latching Functions

POCKET MFSHL V1 TRANSMITTER

Weight	0.7 lbs, 320g (includes battery)
Dimensions	
Height	4.8 in (123 mm)
Width	2.7 in(69 mm)
Depth	1.1 in (28 mm)
Power supply	3 - 1.5V 'AA' batteries
Operation time	Up to 500 hours
Functions	E-Stop pushbutton 2 dual-speed motion pushbuttons 1 on/off start/horn pushbutton
Antenna	Internal

POCKET MFSHL V2 TRANSMITTER

Weight	0.7 lbs, 320g (includes battery)
Dimensions	
Height	4.8 in (123 mm)
Width	2.7 in(69 mm)
Depth	1.1 in (28 mm)
Power supply	3 - 1.5V 'AA' batteries
Operation time	Up to 500 hours
Functions	E-Stop pushbutton 4 dual-speed motion pushbuttons 1 on/off start/horn pushbutton
Antenna	Internal

POCKET MFSHL V3 TRANSMITTER

Weight	0.7 lbs, 320g (includes battery)
Dimensions	
Height	4.8 in (123 mm)
Width	2.7 in(69 mm)
Depth	1.1 in (28 mm)
Power supply	3 - 1.5V 'AA' batteries
Operation time	Up to 500 hours
Functions	E-Stop pushbutton 6 single-speed motion pushbuttons 1 on/off start/horn pushbutton
Antenna	Internal

POCKET MFSHL V5 TRANSMITTER

Weight	0.7 lbs, 320g (includes battery)
Dimensions	
Height	4.8 in (123 mm)
Width	2.7 in(69 mm)
Depth	1.1 in (28 mm)
Power supply	3 - 1.5V 'AA' batteries
Operation time	Up to 500 hours
Functions	E-Stop pushbutton 6 dual-speed motion pushbuttons 1 on/off start/horn pushbutton

RX MFSHL DC8 RECEIVER

Operating power	12/24 VDC (+/- 20%)
Current	<0.8 A (max 1.5W)
Safety features	Safety output monitoring Self-monitoring E-Stop circuits Short circuit protection on ESTOP contact Over-current protection (10A limit) Equipped with solid state relays Self-test during start-up and operation On-board diagnostic system with indicators for RF communication, power status, active outputs
Outputs	8 solid state switching outputs
Antenna	Internal

RX MFSHL AC8 RECEIVER

Operating power	48/220 VAC (+/- 20%)
Current	<0.8 A (max 1.5 W)
Safety features	Safety output monitoring Self-monitoring E-Stop circuits Short circuit protection on ESTOP contact Over-current protection (10A limit) Equipped with solid state relays Self-test during start-up and operation On-board diagnostic system with indicators for RF communication, power status, active outputs
Outputs	8 solid state switching outputs
Antenna	Internal

RX MFSHL AC16 RECEIVER

Operating power	48/220 VAC (+/- 20%)
Current	<0.8 A (max 1.5 W)
Safety features	Safety output monitoring Self-monitoring E-Stop circuits Short circuit protection on ESTOP contact Over-current protection (10A limit) Equipped with solid state relays Self-test during start-up and operation On-board diagnostic system with indicators for RF communication, power status, active outputs
Outputs	16 solid state switching outputs
Antenna	Internal

INSTALLATION AND SAFETY TEST DATA

This form must be completed and signed by the person responsible for installation of this radio remote control system.

Hetronic assumes no responsibility for the correct installation of the radio remote control system. The equipment operator must ensure that the radio remote control system and the crane/machine operate correctly together.

The operator must also ensure that all safety devices and features are in place and operating correctly. The operator is responsible for understanding and following all safety precautions in this and other applicable operator manuals.

Crane/machine Data	
Manufacturer	
Model Number	
Serial Number	
Year of Production	
Radio Remote Control Data	
Manufacturer	Hetronic
Model	
System Type	
Transmitter Production Number	
Receiver Production Number	
System Number	
I/We installed the radio remote control system, performed the safety test and inspected the crane/machine. The appropriate instructions and rules of this crane/machine type are followed.	
Place	
Date	
Company	
Name of Installation Technician	
Signature	

DEFINITIONS

Acoustic signal	A buzzer or other sound intended to be heard as an alert.
Analog signal	Proportional - stepless or infinite control
Belly box	A transmitter that is secured to the front of the operator's body by a belt, strap or breastplate/harness.
Coder	Converts parallel signals into a serial data message
Decoder	Coverts a serial data message into parallel signals
Digital signal	On/off control
Latching control	The function activates when the control is pushed and released. The function stays on until the control is pushed and released again.
Mainline contactor	The primary power supply contactor to the crane/machine controls.
Maintained control	The function activates when the control is placed in the ON position. The function stops when the control is placed in the OFF position.
Momentary control	The function activates when the control is placed in the ON position. The control must be held in place to stay ON. When the control is released, it returns to the OFF position and the function is stopped.
Proportional control	A multi-speed function control that goes faster as the control is pressed further.

AWG - METRIC CONVERSIONS

AWG	Metric Equivalent mm sq.	Metric Cable Size mm sq.
20	0.52	0.75
18	0.82	1.0
16	1.32	1.5
14	2.1	2.5
12	3.3	4
10	5.32	6
8	8.5	10
6	13.5	15
4	21.3	25
2	33.7	35
1/0 (0)	53	70.0 (50.0 if current capacity not exceeded)
2/0 (00)	67.6	70
3/0 (000)	84.4	95
4/0 (0000)	107	120

ABBREVIATIONS

A/D	Analog to digital conversion
AK	Analog channel (German: Analog Kanal)
AMP	Ampere
AWG	American Wire Gauge
BPS	Bits per second
CPU	Central Processing Unit
DK	Digital channel (German: Digital Kanal)
EMC	Electromagnetic compatibility
EMI	Electromagnetic immunity
EPROM	Electrical programmable read-only memory
FM	Frequency modulation
GND	Ground
HF	High frequency
KHz	Kilohertz
LED	Light emitting diode
LTO	Lift to operate
mAH	Milliamperere hours
mA	Milliamperere
msec	Millisecond
MHz	Megahertz
MOV	Metal Oxide Varistor type of surge suppressor
mW	Milliwatt
NiCd	Nickel Cadmium
NiMH	Nickel Metal Hydride
PLC	Programmable logic controller
PLL	Phased locked loop
PTO	Press to operate
PWM	Pulse width modulation
R/C	Resistor/Capacitor type of surge suppressor
RF	Radio frequency
RMS	Root mean squared
Rx	Receiver
RxD	Receiving data
SMD	Surface mount device
SMT	Surface mount technology
TTL	Transistor transistor logic
T-0-T	Toggle switch that is momentary in both directions, OFF in center
Tx	Transmitter
TxD	Transmitting data
Ub	Operating power
Uv	Microvolts
VAC	Volts alternating current
VDC	Volts direct current

WARRANTY

	<h1>Limited Warranty and Terms of Sale</h1>	Hetronic USA
		WRTY_002 Warranty & Terms April 2003

Price: Subject to Change Without Notice
Terms: Net 30 Days
F.O.B: Hetronic USA, Inc.
Oklahoma City, Oklahoma

Hetronic, Inc., hereafter referred to as Company, guarantees all items manufactured by it against any defects of material and/or workmanship for a period of one year from the date of shipment. Company makes NO OTHER WARRANTY, EXPRESSED OR IMPLIED, AS TO THE MERCHANTABILITY OR FITNESS OF THE ITEMS FOR THEIR INTENDED USE OR AS TO THEIR PERFORMANCE. Any statement, description or specification in Company's literature is for the sole purpose of identification of items sold by the Company and imparts no guarantee, warranty or undertaking by Company of any kind. Components and accessories not manufactured by Hetronic are not included in this warranty and are warranted separately by their respective manufacturers.

Company's sole liability shall be to repair at its factory, or replace, any item returned to it within one year from date of shipment, which Company finds to contain defective material or workmanship. All items to be repaired or replaced shall be shipped to Company (Note: return authorization by Company is required) within said one year period, freight prepaid, as a condition to repair or replace defective material or workmanship. Company's herein assumed responsibility does not cover defects resulting from improper installation, maintenance, or improper use. Any corrective maintenance performed by anyone other than the Company during the warranty period shall void the warranty. Company shall not be liable for damages of any kind from any cause whatsoever beyond the price of the defective Company supplied items involved. Company shall not be liable for economic loss, property damage, or other consequential damages or physical injury sustained by the purchaser or by any third party as a result of the use of any Company supplied items or materials.

List prices or discounts are subject to change without notice. Quoted prices will be honored for a period of 90 days from the date of the written quotation unless otherwise stated.

Orders are not subject to alteration or cancellation except upon written consent of Company and payment of proper cancellation charges, when deemed applicable by Company.

Materials or items may not be returned for credit, without the prior written consent of the Company. Any authorized return of materials or items shall be subject to a restocking charge equal to 20% of the net invoiced amount after Company determines that the material or item is in good condition and may be resold without alteration or service.

Terms of payment are NET 30 days. All materials and items are sold F.O.B. Company's shipping point. Company retains a security interest in all items sold by it so long as they remain in Company's possession to secure all obligations of purchaser to Company. A processing fee will be applied to all invoices for requested prepaid freight charges other than UPS. A service charge will be incurred on past due accounts extending beyond the terms of sale described above, at a rate of 1.5% per month of the net balance extending beyond 30 days.

The buyer should inspect the goods immediately on their arrival and shall within five days of their arrival give written notice to the Company of the claim that the goods do not conform with the terms of the contract. If the buyer shall fail to give such notice, the goods shall be deemed to conform with the terms of the contract. Any claim for material or item shortages must be accompanied by copies of the bill of lading and packing slip.

Delivery schedules or commitments are based upon current production capacities, material or component availability and inventory and may be changed as conditions require. Company shall not be liable for loss or damage of any kind resulting from delay or inability to deliver on account of fire, labor troubles, accident, acts of civil or military authorities, or from any other cause beyond Company's control.

